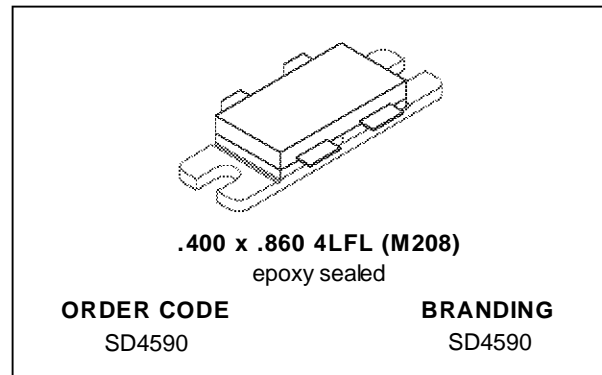
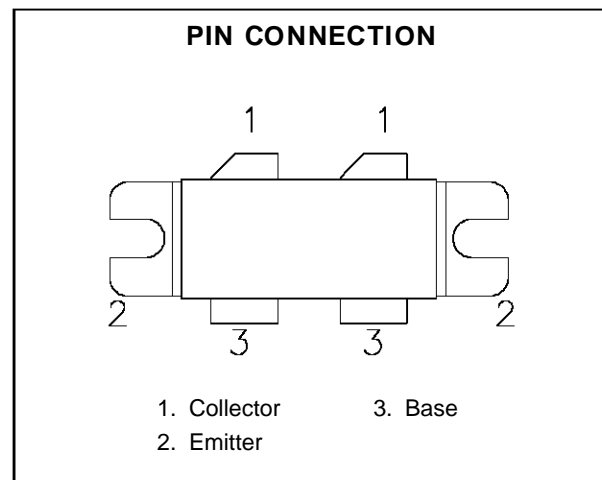

## RF & MICROWAVE TRANSISTORS 800-960MHz CELLULAR BASE STATION

- GOLD METALLIZATION
- DIFFUSED EMITTER BALLASTING
- INTERNAL INPUT/OUTPUT MATCHING
- COMMON EMITTER CONFIGURATION
- DESIGNED FOR LINEAR OPERATION
- HIGH SATURATED POWER CAPABILITY
- 26 VOLT, 900 MHz PERFORMANCE  
 $P_{OUT} = 150 \text{ W MIN.}$   
 $GAIN = 8.5 \text{ dB MIN.}$   
 $IMD_3 = -28\text{dB MAX. @ } P_{OUT} = 150\text{W PEP}$
- INHERENT RUGGEDNESS:  
 LOAD MISMATCH TOLERANCE OF  
 5:1 MIN. VSWR  
 3 dB OVERDRIVE CAPABILITY

**DESCRIPTION**

The SD4590 is designed for both analog and digital cellular base stations over the 800 to 960 MHz frequency range, specifically those systems requiring the high linearity and efficiency afforded by class AB operation. Integrated input/output pre-matching simplifies amplifier design. Ruggedness, MTTF, and linearity are enhanced using diffused emitter resistors and refractory/gold metallization.

**ABSOLUTE MAXIMUM RATINGS** ( $T_{case} = 25^{\circ}\text{C}$ )

Symbol	Parameter	Value	Unit
$V_{CBO}$	Collector-Emitter Voltage	65	V
$V_{CEO}$	Collector-Emitter Voltage	28	V
$V_{EBO}$	Emitter-Base Voltage	3.5	V
$I_C$	Device Current	25	A
$P_{DISS}$	Power Dissipation	300	W
$T_J$	Junction Temperature	+200	$^{\circ}\text{C}$
$T_{STG}$	Storage Temperature	- 65 to +150	$^{\circ}\text{C}$

**THERMAL DATA**

$R_{TH(j-c)}$	Junction-Case Thermal Resistance	0.60	$^{\circ}\text{C/W}$
---------------	----------------------------------	------	----------------------

**SD4590****ELECTRICAL SPECIFICATIONS** ( $T_{case} = 25^{\circ}C$ )

## STATIC

Symbol	Test Conditions	Value			Unit
		Min.	Typ.	Max.	
$BV_{CBO}$	$I_C = 50mA$ $V_{BE} = 0V$	65	80	—	V
$BV_{CEO}$	$I_C = 100mA$ $I_B = 0mA$	28	30	—	V
$BV_{CER}$	$I_C = 100mA$ $R_{BE} = 75\Omega$	33	40	—	V
$BV_{EBO}$	$I_E = 10mA$ $I_C = 0mA$	3.5	4.0	—	V
$I_{CEO}$	$V_{CE} = 30V$ $V_{BE} = 0V$	—	—	10	mA
$h_{FE}$	$V_{CE} = 5V$ $I_C = 6A$	25	45	120	—

Tested per side

## DYNAMIC

Symbol	Test Conditions	Value			Unit
		Min.	Typ.	Max.	
$C_{OB}$	$f = 1.0$ MHz $V_{CB} = 26V$ for information only - this part is collector matched	—	75	—	pF

Tested per side

## DYNAMIC (CW)

Symbol	Test Conditions	Value			Unit
		Min.	Typ.	Max.	
$P_{IN}$	$f = 900MHz$ $V_{CE} = 26V$ $I_{CQ} = 2 \times 200mA$ $P_{OUT} = 150W$	—		21	W
$P_{OUT}$	$f = 900MHz$ $V_{CE} = 26V$ $I_{CQ} = 2 \times 200mA$ $P_{IN} = 21W$	150	175		W
$G_P$	$f = 900MHz$ $V_{CE} = 26V$ $I_{CQ} = 2 \times 200mA$ $P_{OUT} = 150W$	8.5	9.5	—	dB
$\eta_c$	$f = 900MHz$ $V_{CE} = 26V$ $I_{CQ} = 2 \times 200mA$ $P_{OUT} = 150W$	50	55	—	%
$P_{1dB}$	$f = 900MHz$ $V_{CE} = 26V$ $I_{CQ} = 2 \times 200mA$	150	160		W
OVD	$f = 900MHz$ $V_{CC} = 26V$ $I_{CQ} = 2 \times 200mA$ Set $P_{OUT} = 150W$ ; Increase $P_{IN}$ 3dB	No Degradation in Device Performance			

## DYNAMIC (Two-Tone)

Symbol	Test Conditions	Value			Unit
		Min.	Typ.	Max.	
* $G_P$	$V_{CE} = 26V$ $I_{CQ} = 2 \times 200mA$ $P_{OUT} = 150W$ PEP	8.5	9.5	—	dB
* $\eta_c$	$V_{CE} = 26V$ $I_{CQ} = 2 \times 200mA$ $P_{OUT} = 150W$ PEP	30	35	—	%
* $IMD_3$	$V_{CE} = 26V$ $I_{CQ} = 2 \times 200mA$ $P_{OUT} = 150W$ PEP	—	-32	-28	dB
*Load Mismatch	$V_{CE} = 26V$ $I_{CQ} = 2 \times 200mA$ $P_{OUT} = 150W$ PEP $V_{SWR} = 5:1$ MIN @ All phase angles	No Degradation in Device Performance			
*OVD	$V_{CE} = 26V$ $I_{CQ} = 2 \times 200mA$ Set $P_{OUT} = 150W$ PEP; Increase $P_{IN}$ 3dB	No Degradation in Device Performance			

\*Note:  $f_1 = 900.00$  MHz  
 $f_2 = 900.10$  MHz

TYPICAL PERFORMANCE

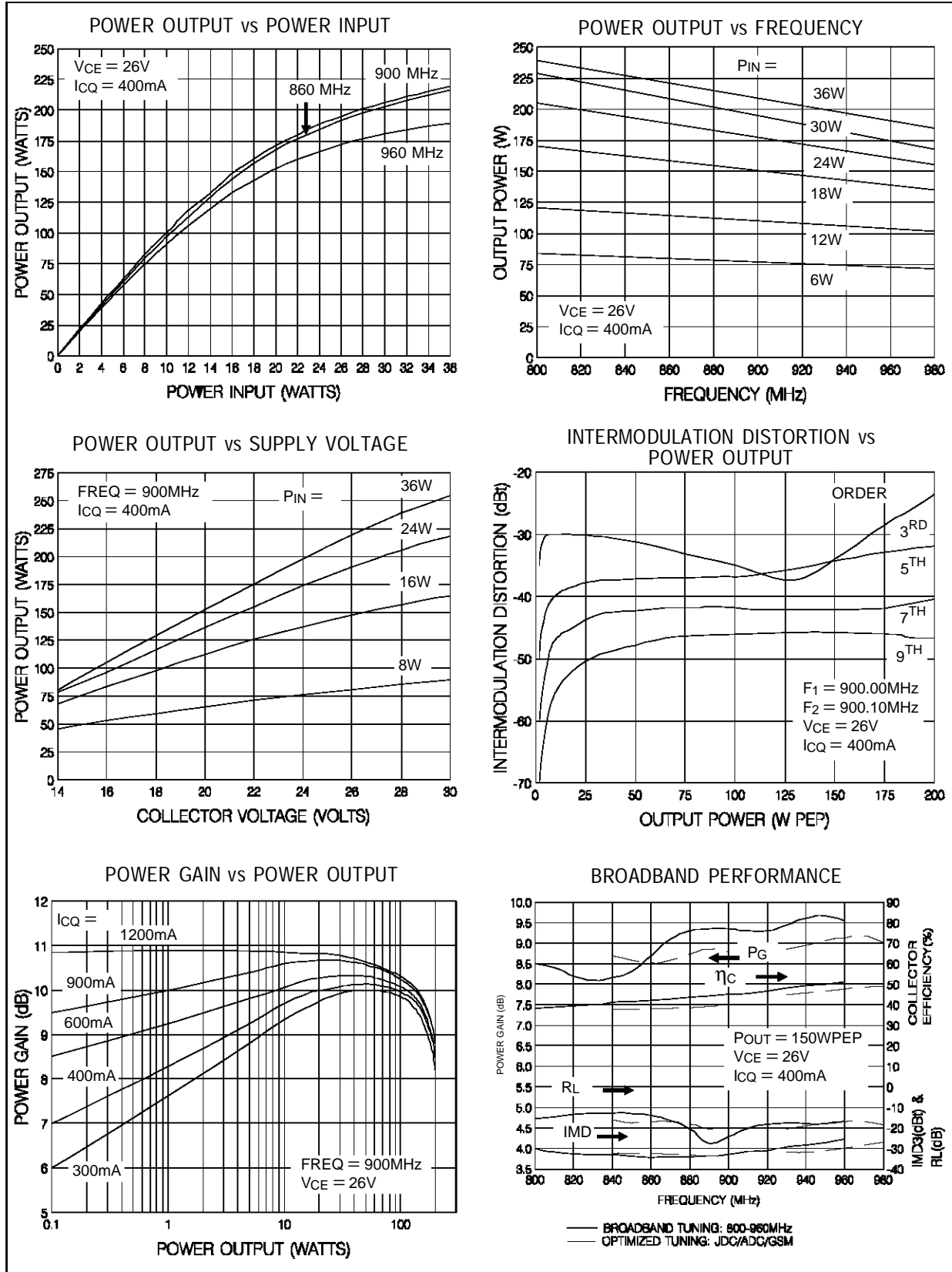

SERIES EQUIVALENT INPUT/OUTPUT IMPEDANCES

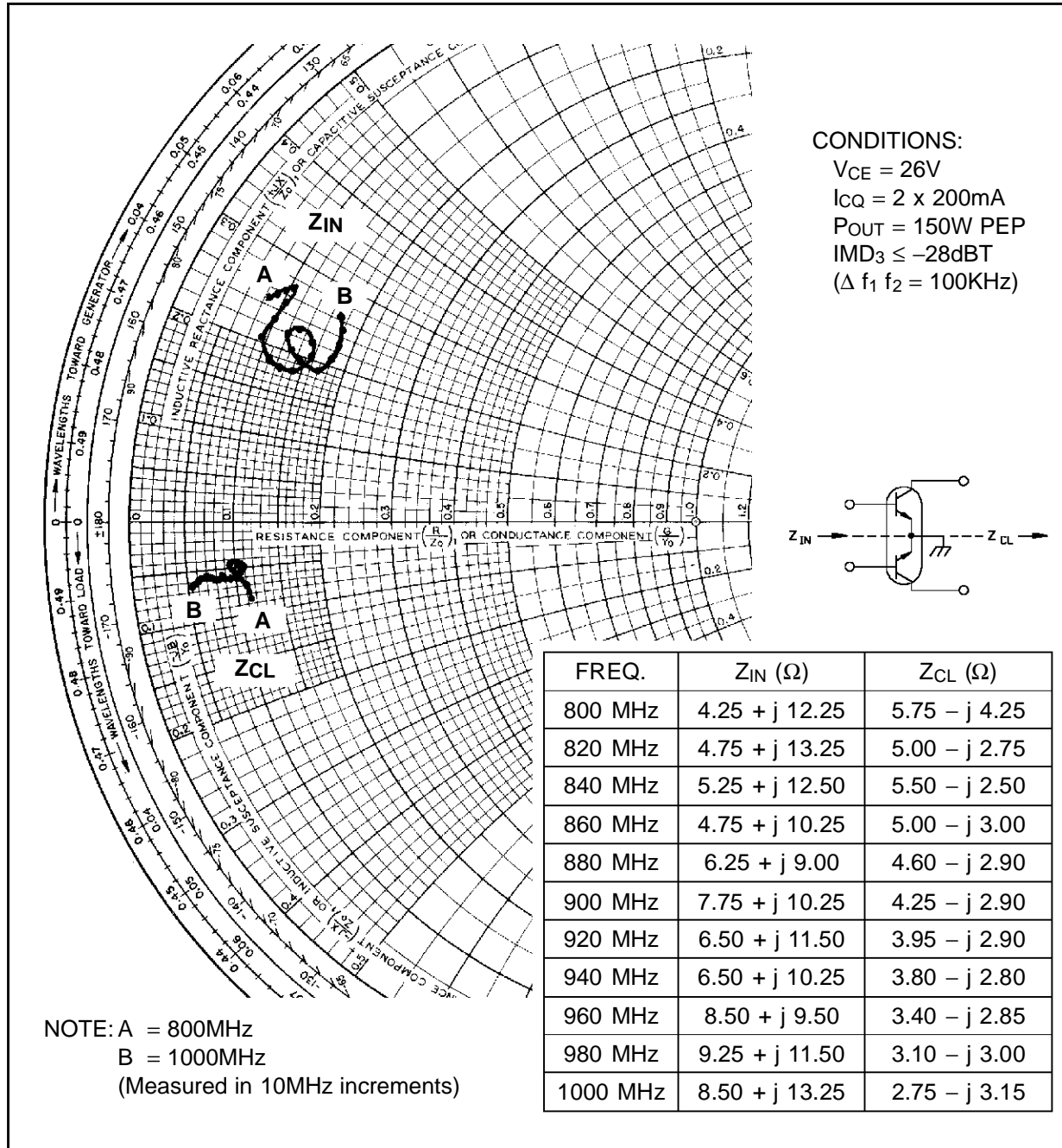

## TEST CIRCUIT

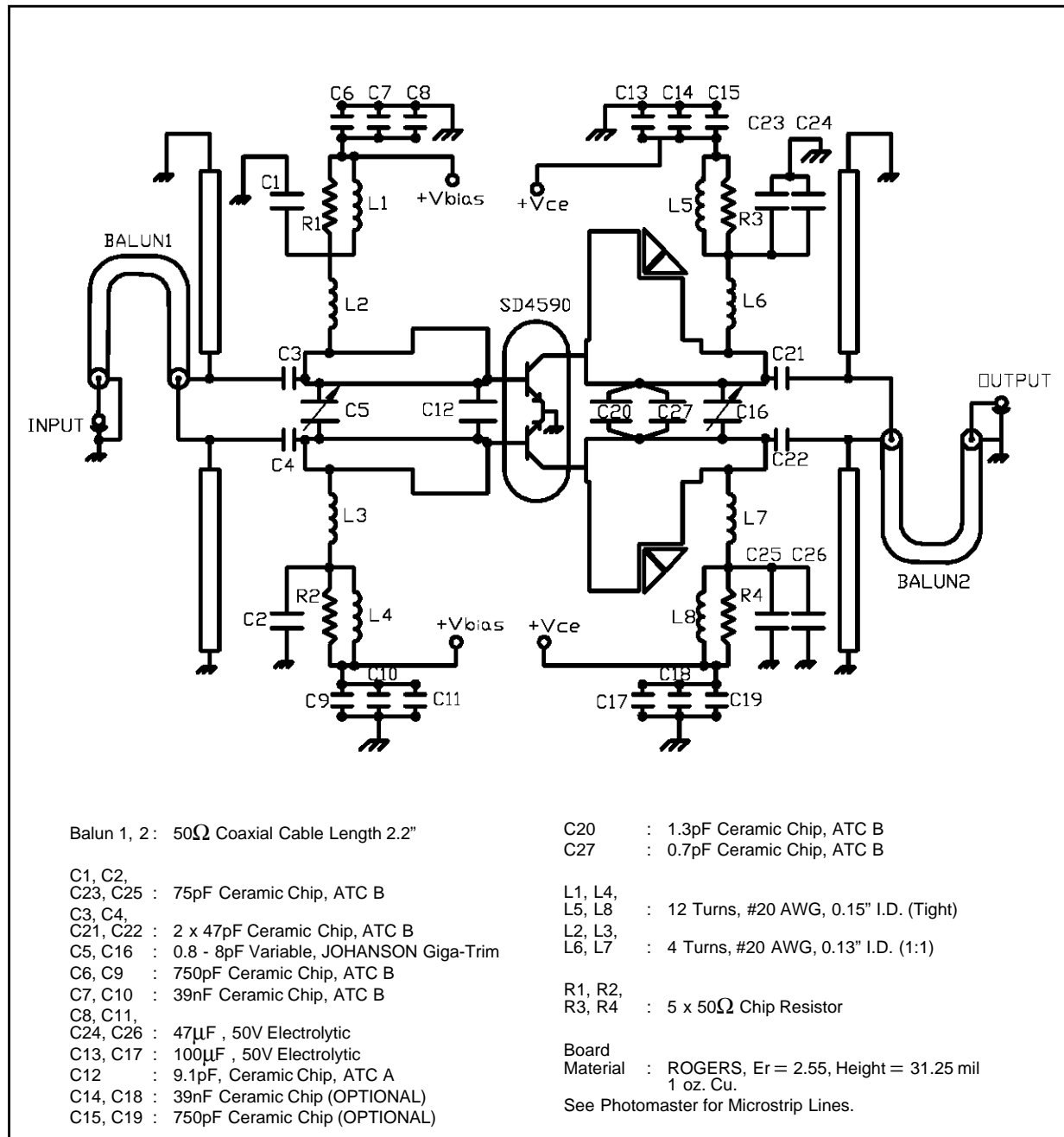

PHOTOMASTER OF TEST CIRCUIT

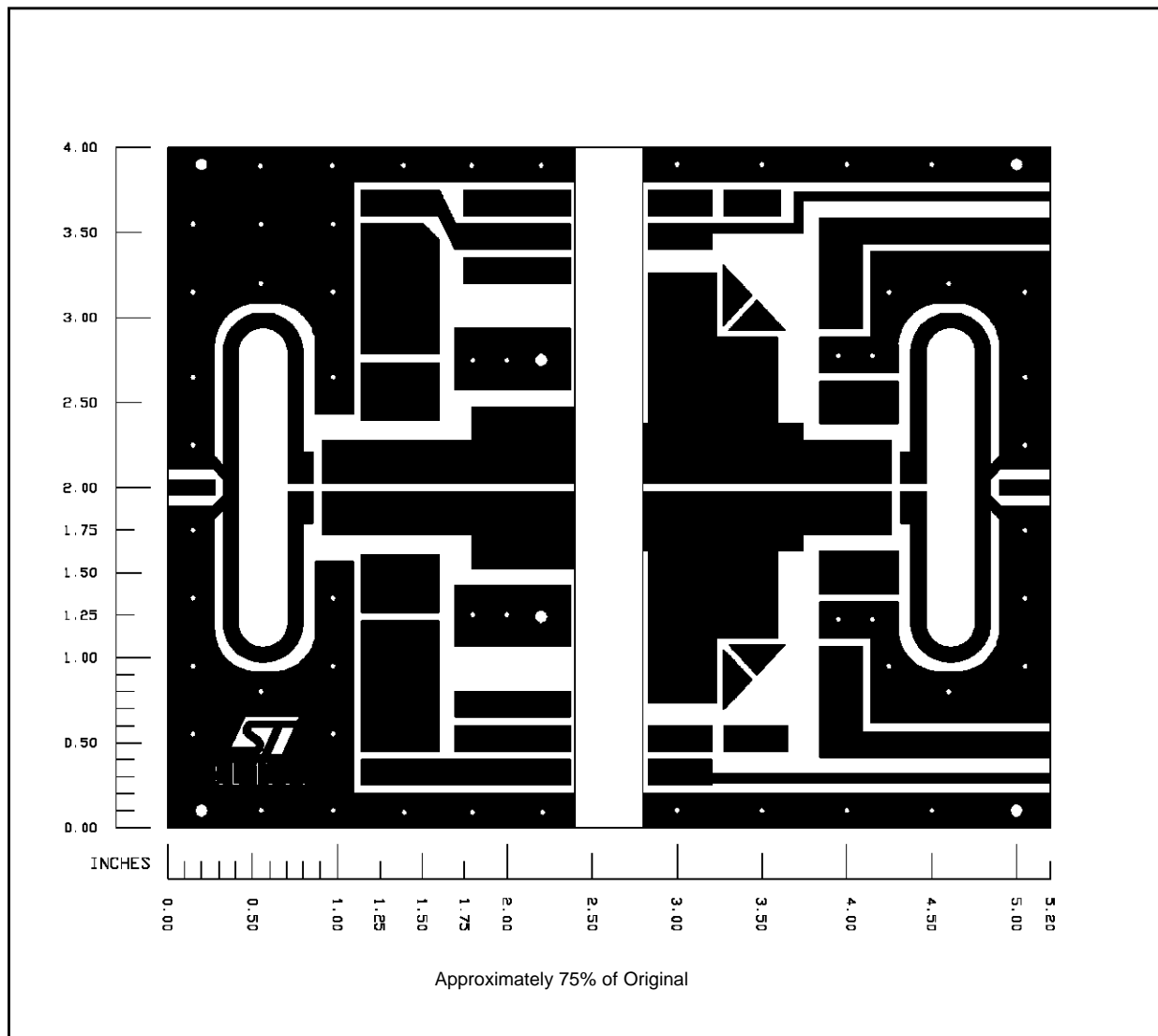

## PACKAGE MECHANICAL DATA

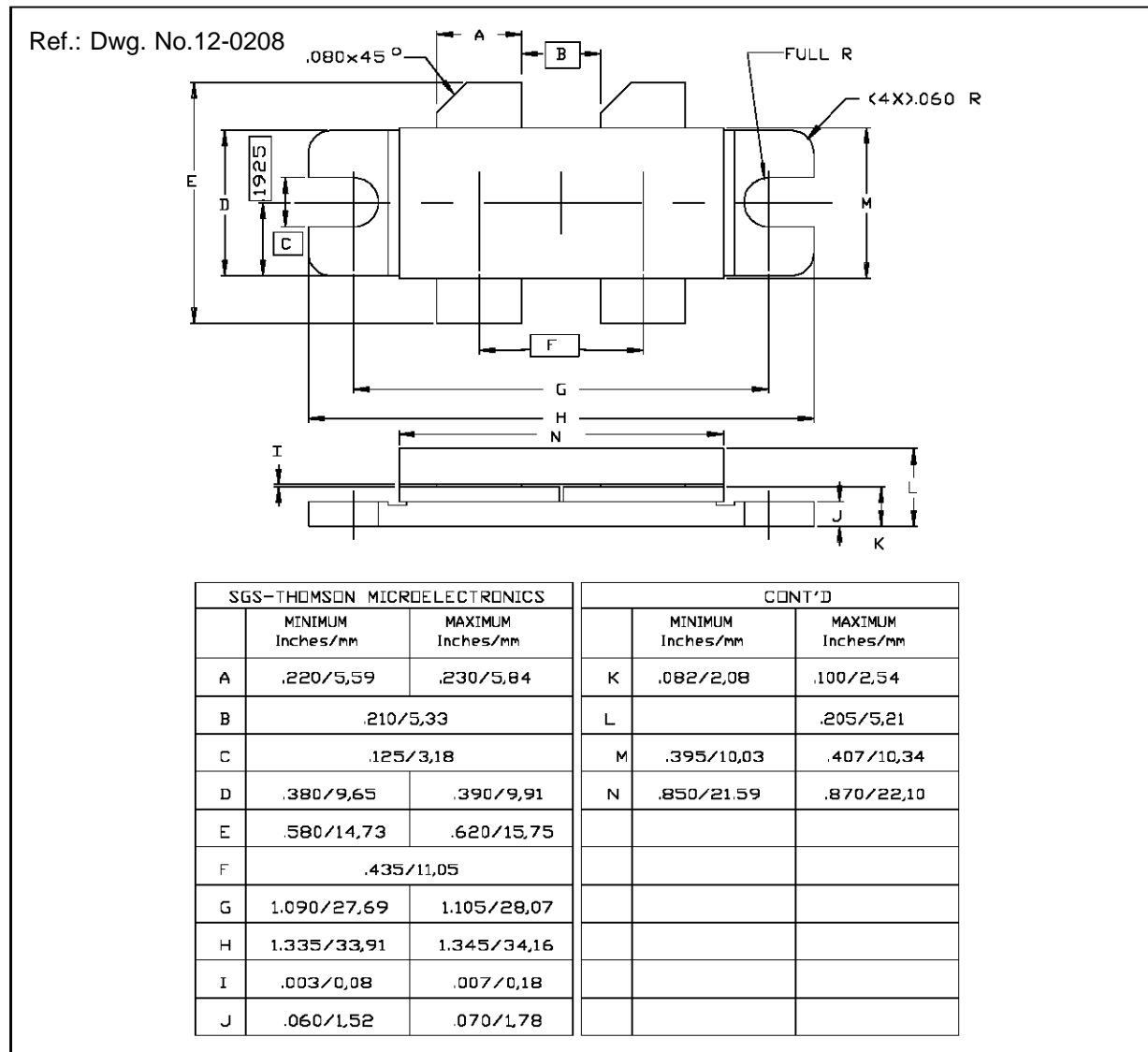

Information furnished is believed to be accurate and reliable. However, SGS-THOMSON Microelectronics assumes no responsibility for the consequences of use of such information nor for any infringement of patents or other rights of third parties which may result from its use. No license is granted by implication or otherwise under any patent or patent rights of SGS-THOMSON Microelectronics. Specifications mentioned in this publication are subject to change without notice. This publication supersedes and replaces all information previously supplied. SGS-THOMSON Microelectronics products are not authorized for use as critical components in life support devices or systems without express written approval of SGS-THOMSON Microelectronics.

© 1994 SGS-THOMSON Microelectronics - All Rights Reserved

SGS-THOMSON Microelectronics GROUP OF COMPANIES  
 Australia - Brazil - France - Germany - Hong Kong - Italy - Japan - Korea - Malaysia - Malta - Morocco - The Netherlands -  
 Singapore - Spain - Sweden - Switzerland - Taiwan - Thailand - United Kingdom - U.S.A